

REVISIONS			
REV	DESCRIPTION	DATE	APPROVED
1	Chg Mat. & finish callout	5/2/12	

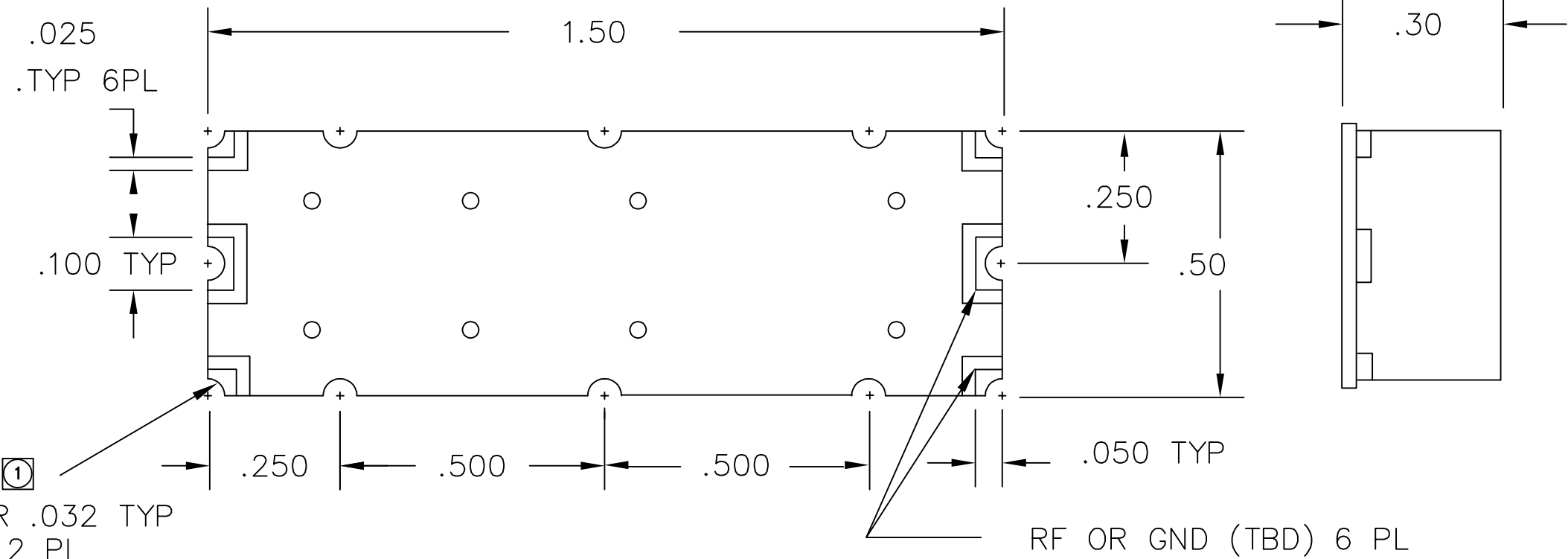

① R .032 TYP  
12 PL  
(PLATED THRU)

RF OR GND (TBD) 6 PL

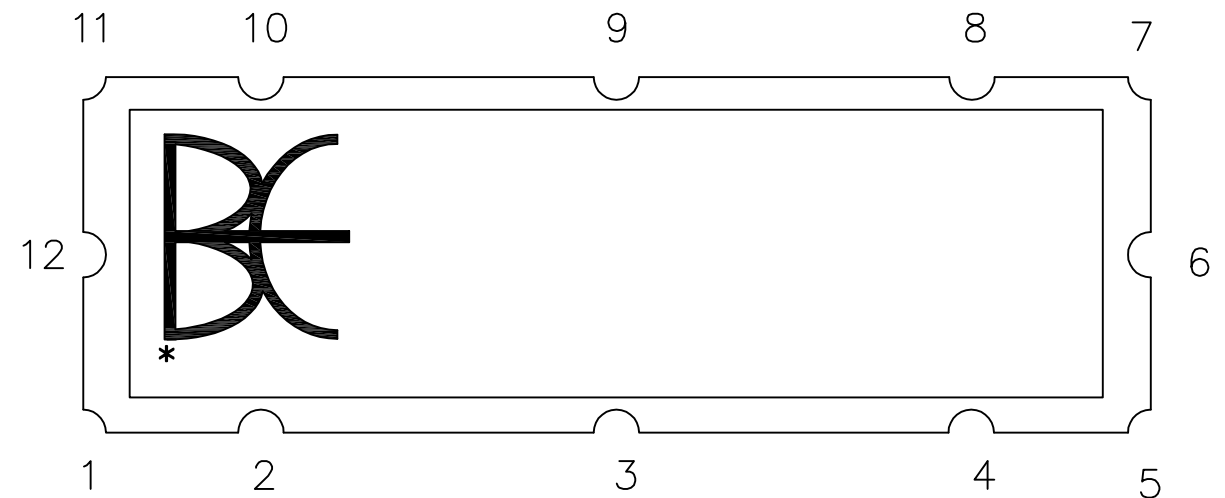

CONTACT I/O  
(TOP VIEW)

① Location of plated thru holes are to be held at +/- .005.

THE INFORMATION CONTAINED IN THIS DRAWING IS THE SOLE PROPERTY OF BREE ENGINEERING. ANY REPRODUCTION IN PART OR WHOLE WITHOUT THE WRITTEN PERMISSION OF BREE ENGINEERING IS PROHIBITED.

UNLESS OTHERWISE SPECIFIED DIMENSIONS ARE IN INCHES & TOLERANCES ARE: .XXX .XX ANGLES ±.005 ±.01	CAD GENERATED DRAWING DO NOT MANUALLY UPDATE		BEE BREE ENGINEERING
	DWN BE	DATE 11-24-99	
MATERIAL NELCO/NICKEL	CHK		OUTLINE
	RESP ENG		
	MFG ENG		
FINISH NICKEL	QUAL ENG		SIZE CAGE CODE DWG NO B 1K3H5 700053
	Scale for REFERENCE ONLY		
SCALE 4:1			REV 1 SHEET 1 OF 1